

Panel Guide 2017



CONTENT

ROLL UP CLASSIC	3
ROLL UP PROFESSIONAL	3
ROLL UP COMPACT	3
4 SCREEN CLASSIC.....	3
POLE SYSTEM.....	3
POP UP MAGNETIC	4-6
POP UP MAGNETIC TOWER.....	4-5
CASE & COUNTER.....	6
STANDARD CASE.....	6
SOFT IMAGE	7
SOFT IMAGE COUNTER	7
FABRIC SYSTEM	8-9
FLAT BASE & MAGNET FRAME.....	10
PANEL BASE.....	11
STAND UP.....	11
INFO STAND.....	12
BROCHURE STAND.....	12
BROCHURE STAND DOUBLE	12
4 BROCHURE.....	12
GRAPHIC PROFILE	12
FLAG SYSTEM	13

Roll Up

Product	Panel size standard	Visible size standard	Panel size telescopic rod	Visible size telescopic rod	Weight
Roll Up Classic 700	700 x 2200	700 x 1950	x	x	3,9
Roll Up Classic 850	850 x 2400	850 x 2150	850 x 2490	850 x 1625 - 2240	4,5
Roll Up Classic 1000	1000 x 2400	1000 x 2150	1000 x 2490	1000 x 1625 - 2240	5,2
Roll Up Classic 1150	1150 x 2400	1150 x 2150	1150 x 2490	1150 x 1625 - 2240	5,8
Roll Up Classic 1450	1450 x 2400	1450 x 2150	x	x	7,3
Roll Up Professional 850	850 x 2400	850 x 2150	x	x	4,8
Roll Up Professional Double	850 x 2400	850 x 2150	x	x	7,3
Roll Up Compact 850	x	x	850 x 2420	850 x 1605 - 2200	3,4
Roll Up Compact 1000	x	x	1000 x 2420	1000 x 1605 - 2200	3,7

Maximum panel thickness is 440 micron. When using 2450 mm supporting rod or stiff material, the recommended thickness is 270-330 micron. When using 2450 mm supporting rod add 300 mm to the panel size. If uncertain we recommend to make tests with different materials.

4 Screen Classic

Product	Panel size	Visible size	Weight
4 Screen Classic 550	550 x 1495	550 x 1481	1,9
4 Screen Classic 700	700 x 1960	700 x 1946	2,2
4 Screen Classic 850	850 x 2160	850 x 2146	2,5
4 Screen Classic 1000	1000 x 2160	1000 x 2146	2,7
4 Screen Classic 1150	1150 x 2160	1150 x 2146	4,1
4 Screen Classic 1450	1450 x 2160	1450 x 2146	4,7
4 Screen Classic 2000	2000 x 2160	2000 x 2146	5,3

4 Screen can handle most materials up to 450 micron thickness (paper, vinyl, pvc, textile). When using 2450 mm supporting rod add 300 mm to the panel size.

Pole System

Product	Panel size width	Panel size height	Weight
Pole System 550	550	optional, max 2400	2,6
Pole System 700	700	optional, max 2400	2,7
Pole System 850	850	optional, max 2400	2,8
Pole System 1000	1000	optional, max 2400	2,9

Pole System can also be used as double sided. In this case an extra panel profiles should be added. Pole System can handle most materials up to 450 micron thickness (paper, vinyl, pvc, textile). Total height of the system is min 1000 mm and maximum 2560 mm.

Panel profile dimension sketch

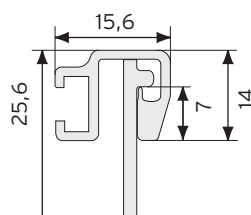

Pop Up Magnetic - panel sizes

Curved system

Product	Standard height	2,5 m height	3 m height
Curved, inside	673x2224	673x2483	673x2957
Curved, outside	808x2224	808x2483	808x2957
Side panel, curved	673x2224	673x2483	673x2957
Side panel, straight	293x2224	293x2483	293x2957

Straight system

Product	Standard height	2,5 m height	3 m height
Straight panel	733x2224	733x2483	733x2957
Side panel, curved	733x2224	733x2483	733x2957
Side panel, straight	293x2224	293x2483	293x2957

Connected systems

Product	Standard height	2,5 m height	3 m height
90° connection, inside	265x2224	265x2483	265x2957
90° connection, outside	733x2224	733x2483	733x2957
Straight connection	733x2224	733x2483	733x2957

Pop Up Magnetic - weights

Product	Basic		Travel		Standard		Case & Counter*		Top shelf
	Curved	Straight	Curved	Straight	Curved	Straight	Curved	Straight	C&C
Package 2x3	8,5	8,8	15,5	15,8	23,0	23,3	26,5	26,8	5,3
Package 3x3	10,4	10,8	18,0	18,4	25,5	25,9	29,0	29,4	5,3
Package 4x3	12,3	12,8	20,0	20,5	27,5	28,0	31,0	31,5	5,3

*The top shelf is not included in the Case & Counter package.

Pop Up Tower

Product	Qty panels	Panel size	Diameter	Weight
Tower 3 squares high	3 pcs	673x2224	643	5,5

Tower panel thickness should be 350 - 420 micron, as they should be pliable. These panels should not have kickers.

Pop Up Magnetic - accessories

Product	Standard height + recommended width
Curtain	2215 x 1300

Product	Maximum load straight system	Maximum load curved system	Weight
Screen Holder	6,00*	8,00	1,1
Shelf Kit	4,65*	6,65	2,4

* Stabilizing feet code 7365 should be used for straight system. Screen Holder and Shelf Kit may only be used with Expolinc Pop Up Magnetic.

Pop Up Magnetic - dimension sketches

Example 3 squares

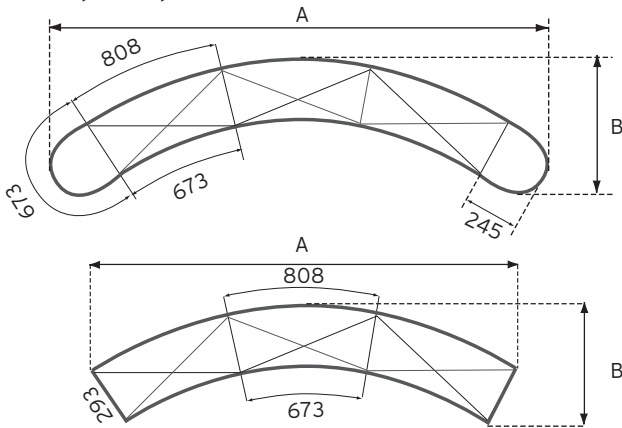

Curved system

Width	Curved side panels		Straight side panels	
	A	B	A	B
1 square	1225	375	846	350
2 squares	1915	510	1607	461
3 squares	2535	710	2290	639
4 squares	3065	970	2860	877
5 squares	3600	1250	3289	1161

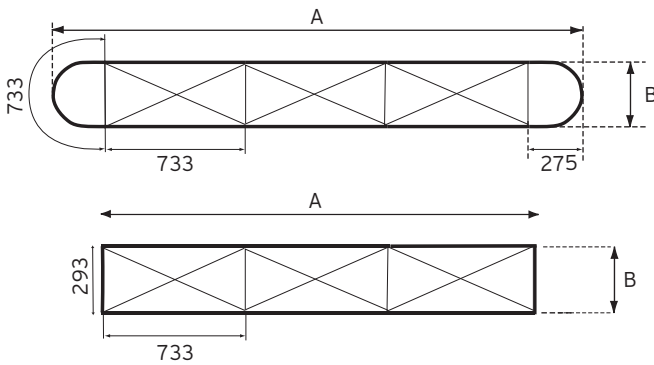

Straight system

Width	Curved side panels		Straight side panels	
	A	B	A	B
1 square	1283	315	779	315
2 squares	2016	315	1512	315
3 squares	2749	315	2245	315
4 squares	3482	315	2978	315
5 squares	4215	315	3711	315

Straight connection

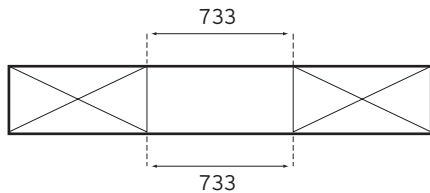

90° connection

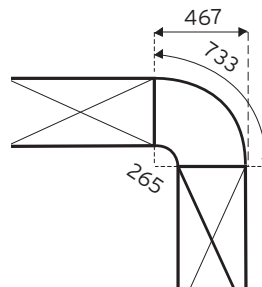

Radius

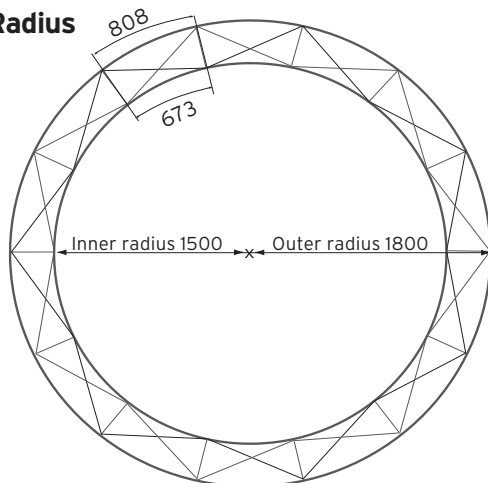

Tower

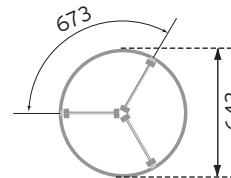

Screen Holder & Shelf kit - dimension sketches

Position of holes in panel for Screen Holder/Shelf kit

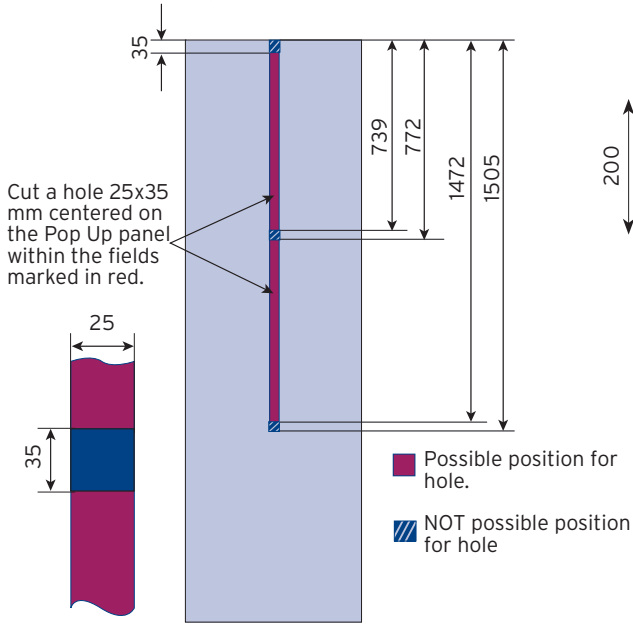

Shelf Kit

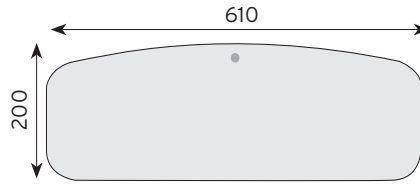

Screen plate

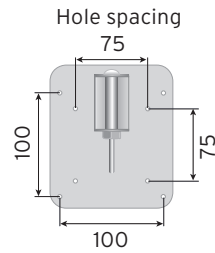

Screen Holder

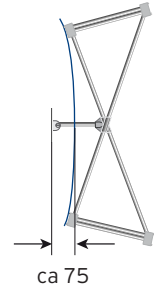

Suspension options

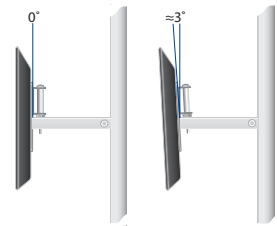

Transport boxes

Product	Panel size	Weight
Case & Counter	1820 x 920	16,5*
Standard Case	1585x840	10,8

Recommended panel thickness 350 - 420 micron. *Top shelf is not included in Case & Counter. Weight top shelf 5.3 kg

Case & Counter

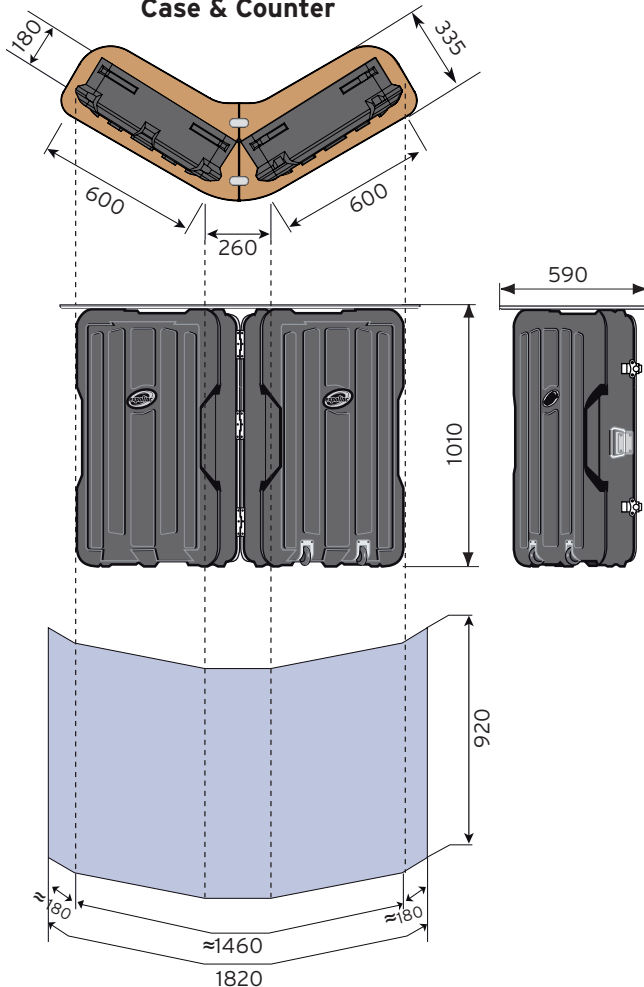

Standard Case

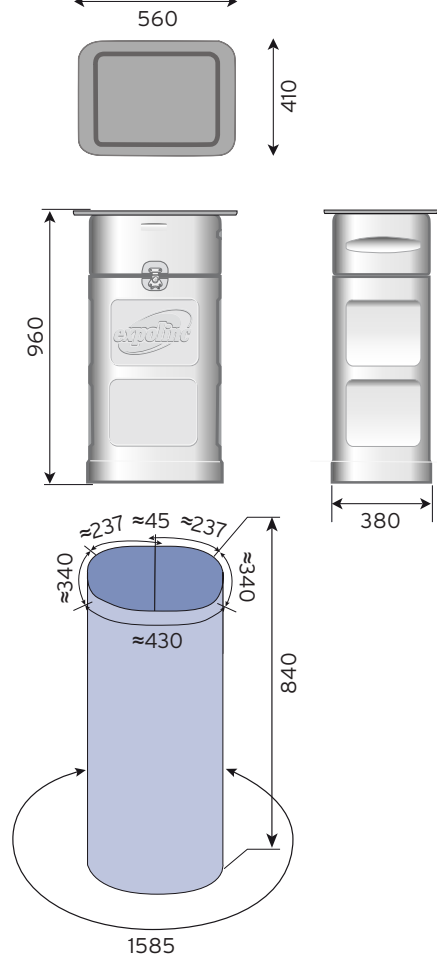

Soft Image

Product	Panel size front textile	Panel size covered sides	Weight*
Soft Image 2 x 3	1510 x 2240	2150 x 2240	7,0
Soft Image 3 x 3	2240 x 2240	2880 x 2240	9,2
Soft Image 4 x 3	2970 x 2240	3610 x 2240	11,14
Soft Image 5 x 3	3700 x 2240	4340 x 2240	13,6

*Weight frame only. The above sizes are the actual sizes. As textile is elastic the size may vary.

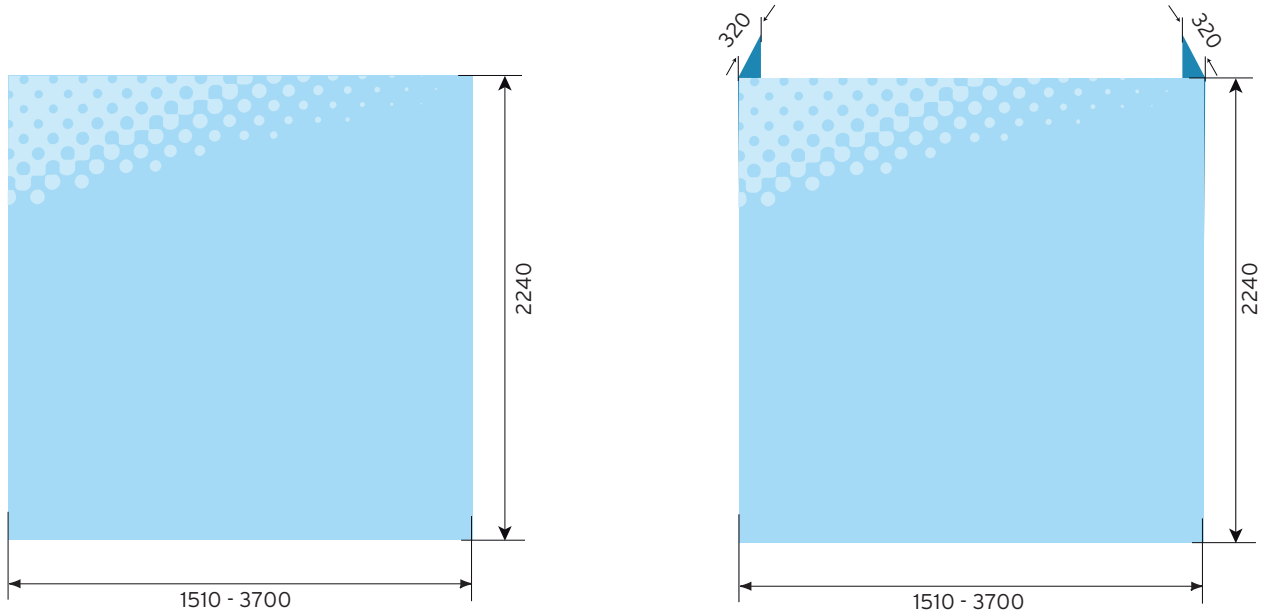

Soft Image Counter

Product	Size textile front and sides	Weight
Soft Image Counter alt 1	1640 x 990	10,5
Soft Image Counter alt 2	1740 x 990	10,5

The above sizes are the actual sizes. As textile is elastic the size may vary.

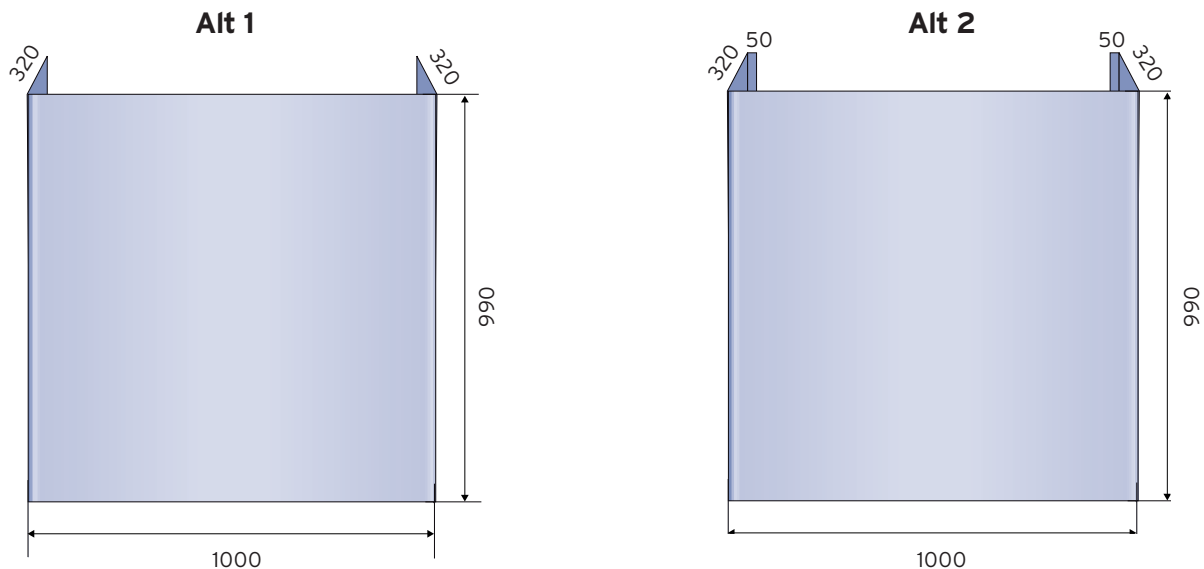

Fabric System

Product	Max building width mm	Graphic height mm	Graphic width mm
2 Poles straight	4400	1000 - 2750	Profile lengths+sides
2 Poles curved 15°	3300	1000 - 2750	Profile lengths+sides
3 Poles curved 15°	6600	1000 - 2750	Profile lengths+sides
3 Poles straight	6600	1000 - 2750	Profile lengths+sides
3 Poles curved 90°+straight	6800	1000 - 2750	Profile lengths+sides

Max system height 2900 mm

Profile lengths

Straight profile, can be cut into desired length	1100
Curved profile 15°, inner radius	1100
Curved profile 15°, outer radius	1100
Curved profile 90°, inner radius	1300



Curved profile 15° 1100 mm
Graphic on outer radius 4,2 m.



Curved profile 15° 1100 mm
Graphic on inner radius 4,2 m.



Straight profile 1100 mm
Can be cut into desired length.

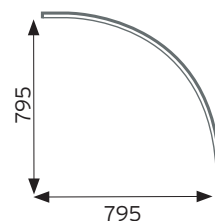

90° inner curve 1300 mm
Graphic on inner radius 0,8 m.

Weight packages

Weight*

Soft bag and 2 poles	16,50
Standard Case XL and 2 poles	29,00
Standard Case XL and 3 poles	35,00
Profiles, straight and curved 15°	0,50
Profile curved 90°	0,55

*Weight excl profiles. Combine packages for larger building widths.



Recommended size of the graphic strip is 3x12mm in soft PVC or silicone.



Add 100 mm on each side to fold sides + seams at the top and bottom.

Standard Case XL

Product	Panel size	*Weight kg	Weight top shelf
Standard Case XL	1585 x 840	11,5	2,5 kg

Recommended panel thickness 350 - 420 micron. *Top shelf, locking kit and papertube for panel are not included in Standard Case XL.

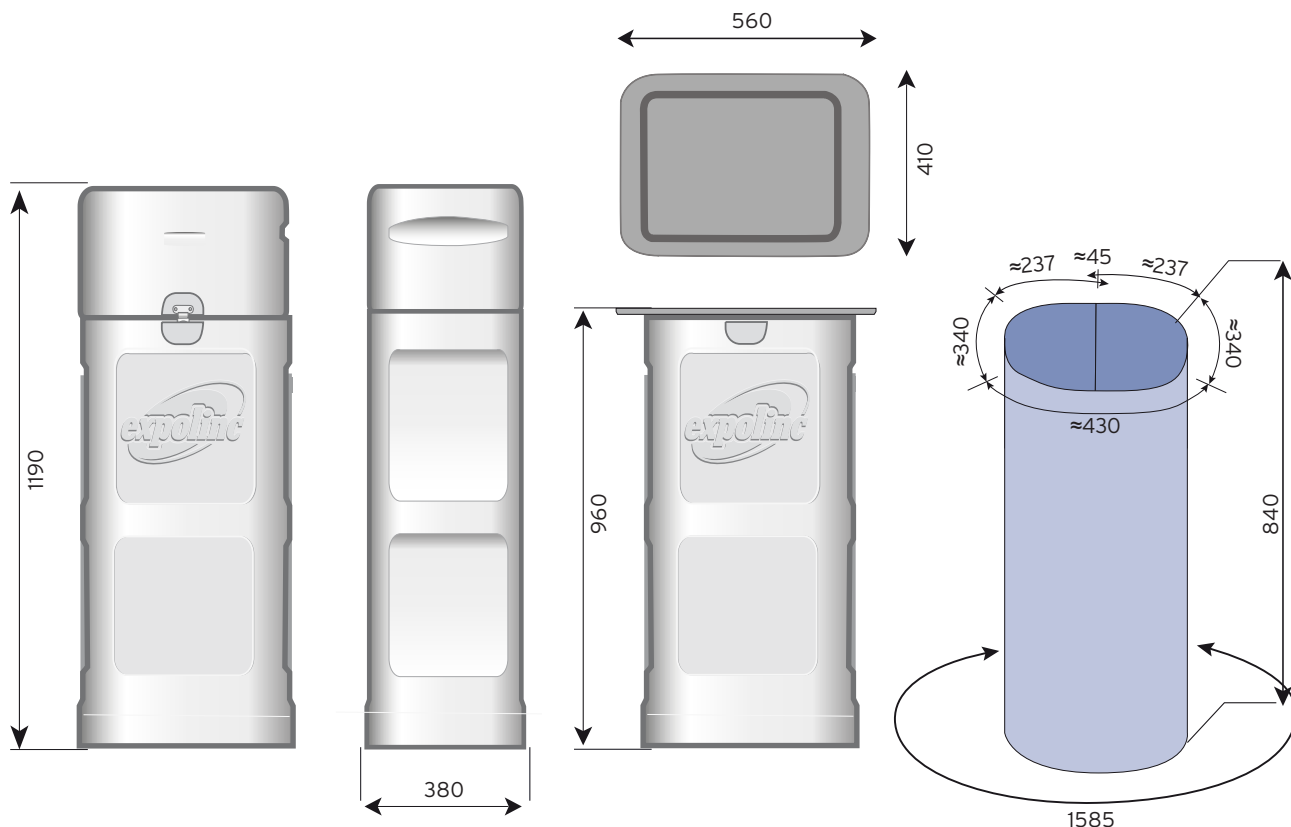

Some examples

Top and bottom profiles Graphic width incl 100 mm on each side.

4 pcs inner curve 2 400 mm

6 pcs inner curve 3 500 mm

8 pcs inner curve 4 600 mm

10 pcs inner curve 5 700 mm

12 pcs inner curve 6 800 mm

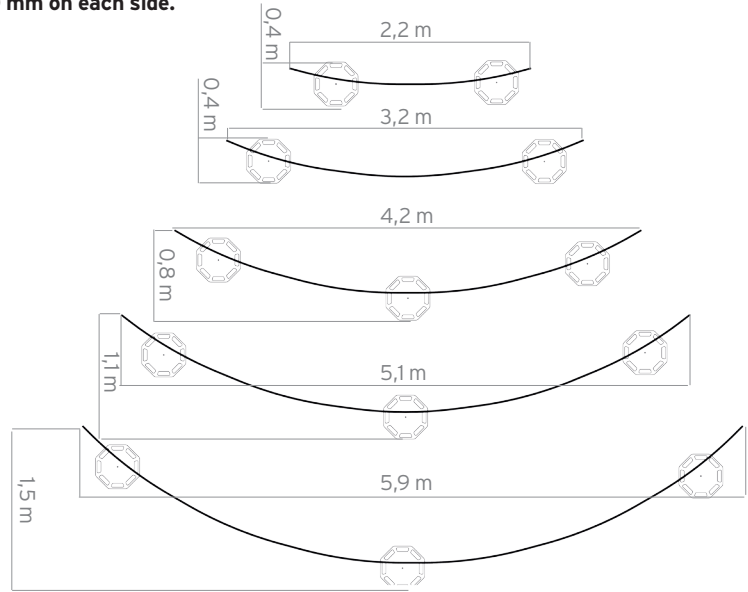

Total curve 30-45-60-75 resp 90 degrees

8 pcs straight 4 600 mm



4 pcs inner curve
4 pc outer curve 4 600 mm

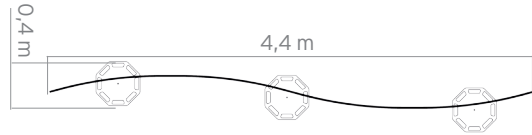

6+4 pcs straight
2 pc curved 90° 7 000 mm

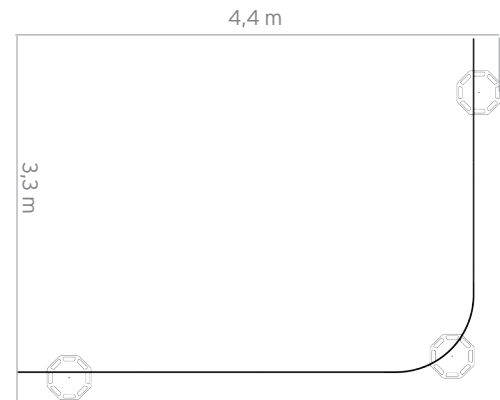

12 pcs straight
4 pcs curved 90° 9 400 mm

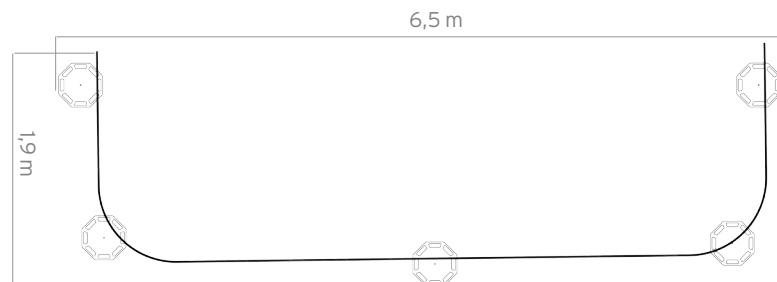

Flat Base

Product	Weight
Flat Base 400	1,1
Flat Base 610	1,7

Flat Base 400

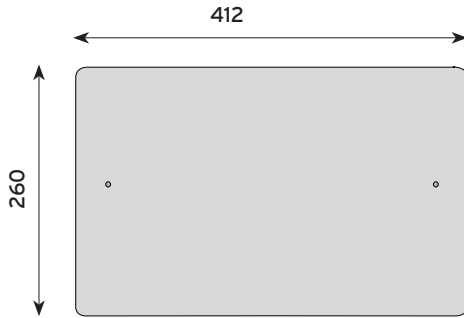

Flat Base 610

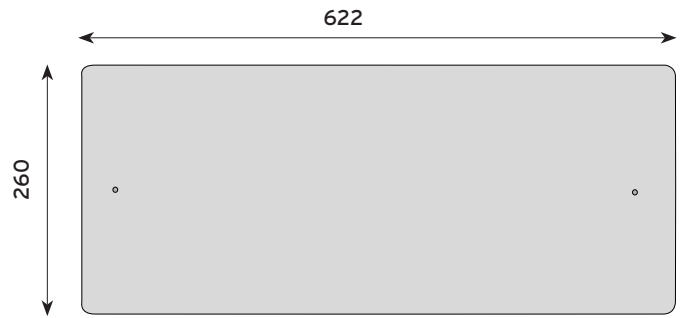

Magnet Frame

Product	Qty panels	Frame dimensions	Panel size with		Weight
			Flat Base	Panel Base	
400 x 1600	2 pcs	405 x 1590	400 x 1585	400 x 1535	1,8
400 x 1800	2 pcs	405 x 1790	400 x 1785	400 x 1735	1,9
610 x 1600	2 pcs	615 x 1590	610 x 1585	610 x 1535	2,0
610 x 1800	2 pcs	615 x 1790	610 x 1785	610 x 1735	2,1

Recommended panel thickness 350x420 micron.

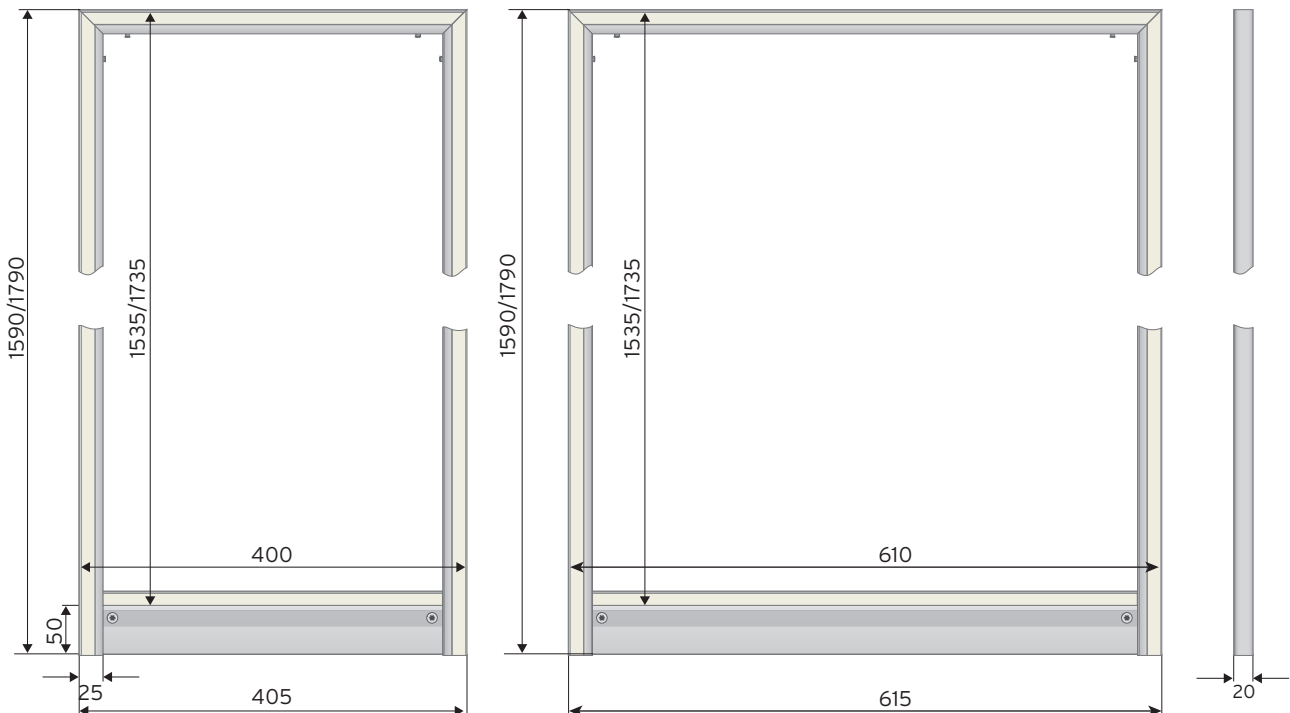

Panel Base

Product	Qty panels	Max panel thickness	Weight
Panel Base 80 (pair)	1 pc	19	0,7
Panel Base 400	1 pc	19	1,7
Panel Base 610	1 pc	19	2,5

Panel Base can handle most materials up to 19 mm thickness. Recommended max panel height ca 1800 mm depending on the material. Please note that 50 mm at the bottom will be invisible in the systems L-extrusion.

Panel Base 80

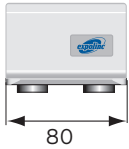

Panel Base 400

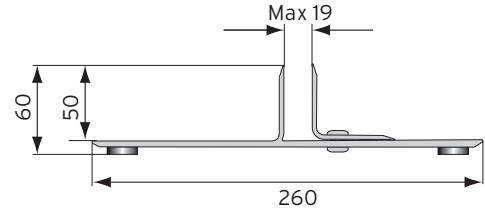
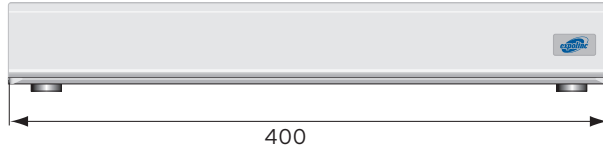

Panel Base 610

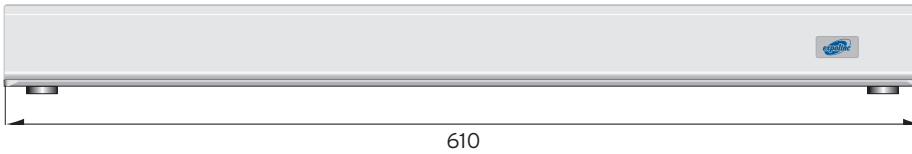

Stand Up

Product	Qty panels		Panel size	Visible size	Weight
Universal Counter	1 pc	Front	700 x 950	690 x 940	17,5
	4 pcs	Sides	285 x 950	275 x 940	
Info Counter	1 pc	Front	700 x 950	690 x 940	9,5
	2 pcs	Sides	285 x 950	275 x 940	

Maximum panel thickness 7 mm. Use clips in thickness <5 mm.

Stand Up Universal Counter

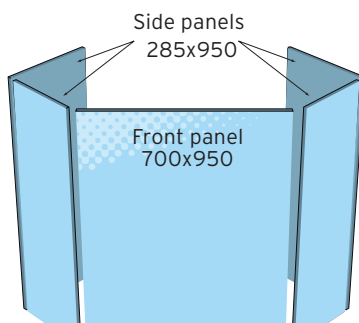
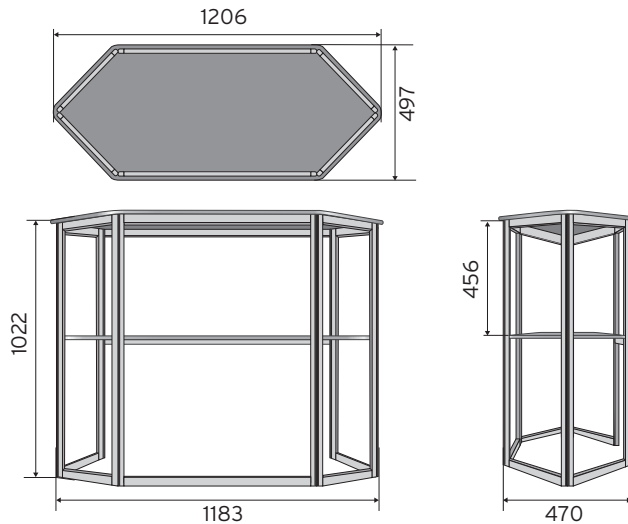

Stand Up Info Counter

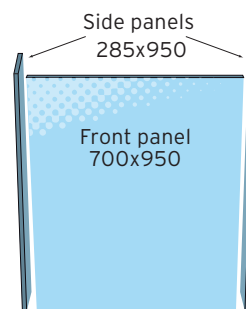
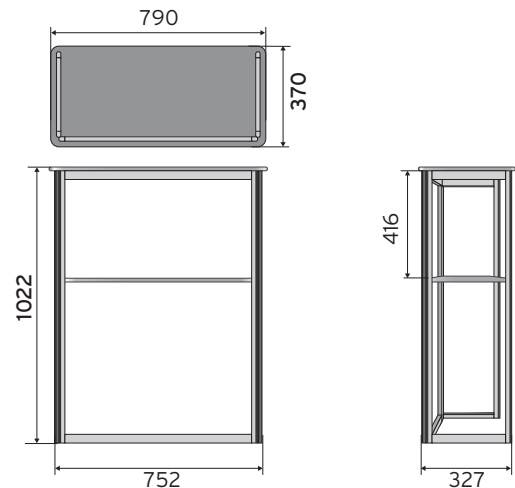

Info Stand

Product	Max image size	Visible size	Weight
Info Stand - straight	297x420 (landscape A3)	284x420	4,8
Info Stand - angled	210x297 (portrait A4) <i>or</i> 297x210 (landscape A4)	210x297 (portrait A4) <i>or</i> 297x210 (landscape A4)	5,2

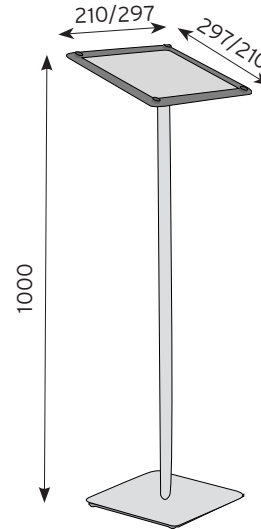
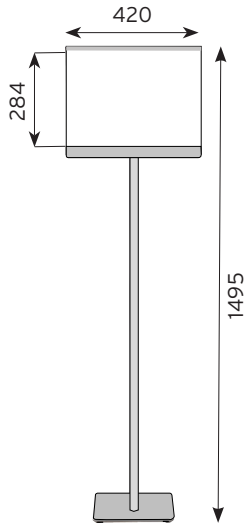

Brochure Stand

Product	Qty holders	Size of holder	Weight
Brochure Stand with soft bag	4 pcs A4	220 x 330	4,9
Brochure Stand with hard case	4 pcs A4	220 x 330	8,4

Brochure Stand Double

Product	Qty holders	Size of holders	Weight
Brochure Stand Double with soft bag	5 pcs A4	220 x 330	5,2
Brochure Stand Double with hard case	5 pcs A4	220 x 330	8,7

4 Brochure

Product	Qty pockets	Size of pockets	Weight
4 Brochure 4xA4	4 pcs A4 textile pockets for max 75 sheets	260 x 260	1,7
4 Brochure 8xA4	8 pcs A4 textile pockets for max 50 sheets	260 x 260	1,9

Graphic Profile

Product	Max thickness mikron	Weight Kg/m
All versions	800	0,35

Flag System

Flag sizes	Total fabric size	Visible size
Flag System - curved flag	1060 x 3700	1000 x 3700
Flag System - rectangular flag	1060 x 2670	1000 x 2650
Rectangular with extra pole section	1060 x 3670	1000 x 3650

Specified heights refers to the maximum height of the flag. At wind >6 m/s we recommend extra weight.

Weight packages	Weight
Flag System with X-foot	9,5
Flag System with ground stake	3,0

Curved flag

Add fabric (70-80 mm) in addition to the image area to sew a 60 mm wide pocket together with the extra separate fabric part for the flag pole.

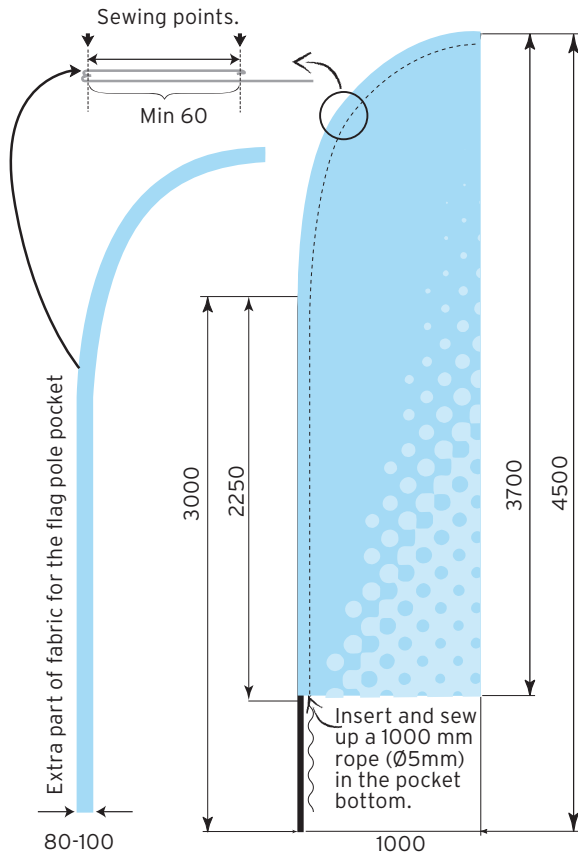

Rectangular flag

Add fabric, in addition to the image area, to sew two pockets.

- 70-80 mm for the 60 mm wide pocket for the flag pole.
- 30-40 mm for the 20 mm wide pocket for the horizontal fibre glass pole

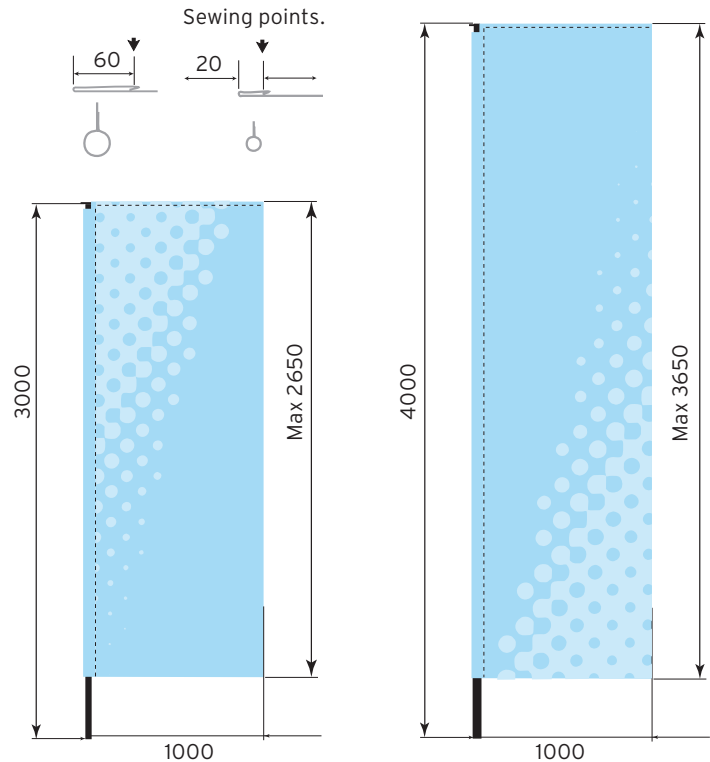



HEAD OFFICE Expolinc AB, Archimedesvägen 6, SE-168 66 Bromma, Sweden. Tel +46-8-54644400. info@expolinc.se www.expolinc.com
US OFFICE Expolinc Co., 140 North Main Street, Mount Gilead, OH 43338. TOLL FREE 1-800-319-0025. info@expolinc.us www.expolinc.us
GERMAN OFFICE: Expolinc GmbH, Schulze-Delitzsch Str. 8, Heddesheim. Tel +9(O)6203 938480, info@expolinc.de www.expolinc.de